

**HERCULES HOISTS LIMITED**

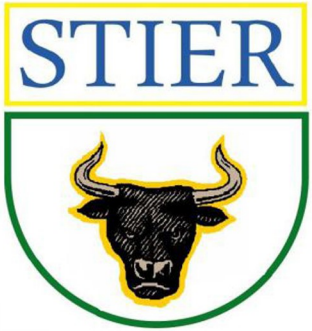

# RATCHET LEVER HOIST

- ◆ Lifting
- ◆ Moving
- ◆ Storing



**STEIR™** Ratchet Lever Hoist with the best of German technology offers perfectly designed housing, gear, reinforced frame, brake and fully chrome plated body.

- Capacities up to 9T.
- Easy free chaining: with selector lever set to middle position, the load chain and hook can be pulled into required position effortlessly.
- Load chain: galvanized and tempered high tensile load chain compliant with DIN norms, standard 1.5m length, longer lengths possible against order.
- Chain guide: leads the load chain properly into sprocket wheel without jamming and sticking.
- Protected hand grip: prevents manual slipping and hurting of fingers.

**Material Handling. Delivered**

**Redefining Material Handling. Since 1962.**

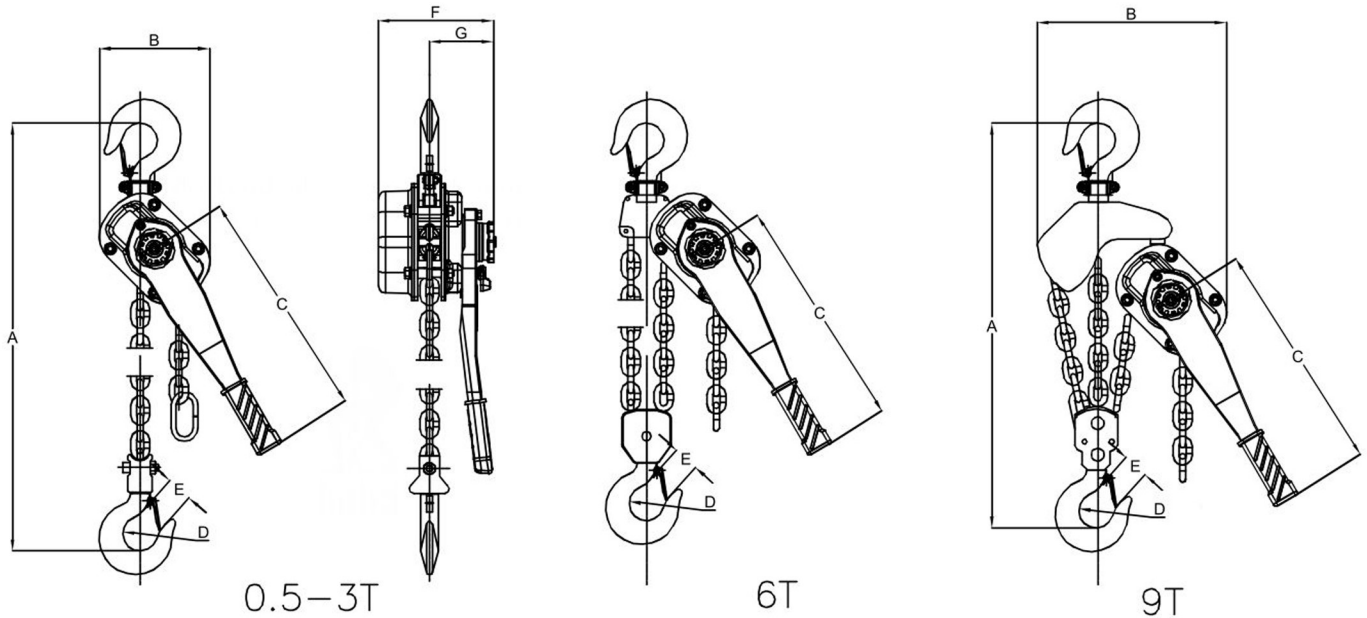

HHL/PLH Premium/20140201/V2

Capacity	t	0.75	1.5	3	6	9
Standard Lift	m	1.5	1.5	1.5	1.5	1.5
Min. Headroom (A)	mm	330	40	400	640	795
Lever Force	daN	26	29	29	37	42
Number of chain Falls		1	1	1	2	3
Chain Size	mm	5.6X17	7.1X21	10X28	10X28	10X28
B (Dimensions)	mm	132	145	199	230	338
C	mm	278	378	388	388	388
D	mm	35	42	50	53	67
E	mm	27	33	40	42	53
F	mm	148	173	200	200	200
G	mm	87	99	112	112	112
Weight with Standard Lift	kg	6.5	10.2	22	34	45
Lifting Height	kg	0.7	1.1	2.2	4.4	6.6

Note :- Due To Continuous development and improvement specification listed above may be changed

## HERCULES HOISTS LIMITED

Authorised Distributor



### ELEQUIP TOOLS PVT. LTD

19 Pollock Street 2nd Floor  
 Kolkata 700 001 W.B  
 Tel: +91 9674322200 / (033)22351792  
 www.ehoists.in | contact@ehoists.in